

Features

- System power :120W
- Aluminium housing and tempered glass cover
- RGBW color with round beam angles
- DMX512 control system to achieve gradual, transition, blinking and other dynamic effects

Highlights

- High brightness with robust design
- Excellent heat dissipation
- Flexible base for angle adjustment
- Field installation friendly
- Cost effective

Technical Drawing

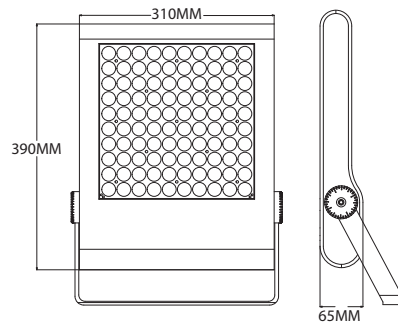

Technical Specifications

Tolerance: ±2.5mm

Article Number		AB-B0h-FG-GA2Bx0
Product	LED type	SMD LED
	Beam angle	8° / 18° / 30° / 40°
	Color	RGBW
Environmental	Operating temperature	-30°C To 45°C
	Operating humidity range	10 - 90% RH
	Ingress protection	IP66
	LED lifetime	50,000hrs
Power	Mains input	90-264VAC
	Power consumption maximum	120W
Physical	Housing	Aluminium
	Cover	4mm Tempered Glass
	Dimensions (L x W x H)	310mm x 65mm x 390mm
Control	Control system	DMX512

x : Beam angle
R= 8°, J= 18°, D= 30°, M= 40°